

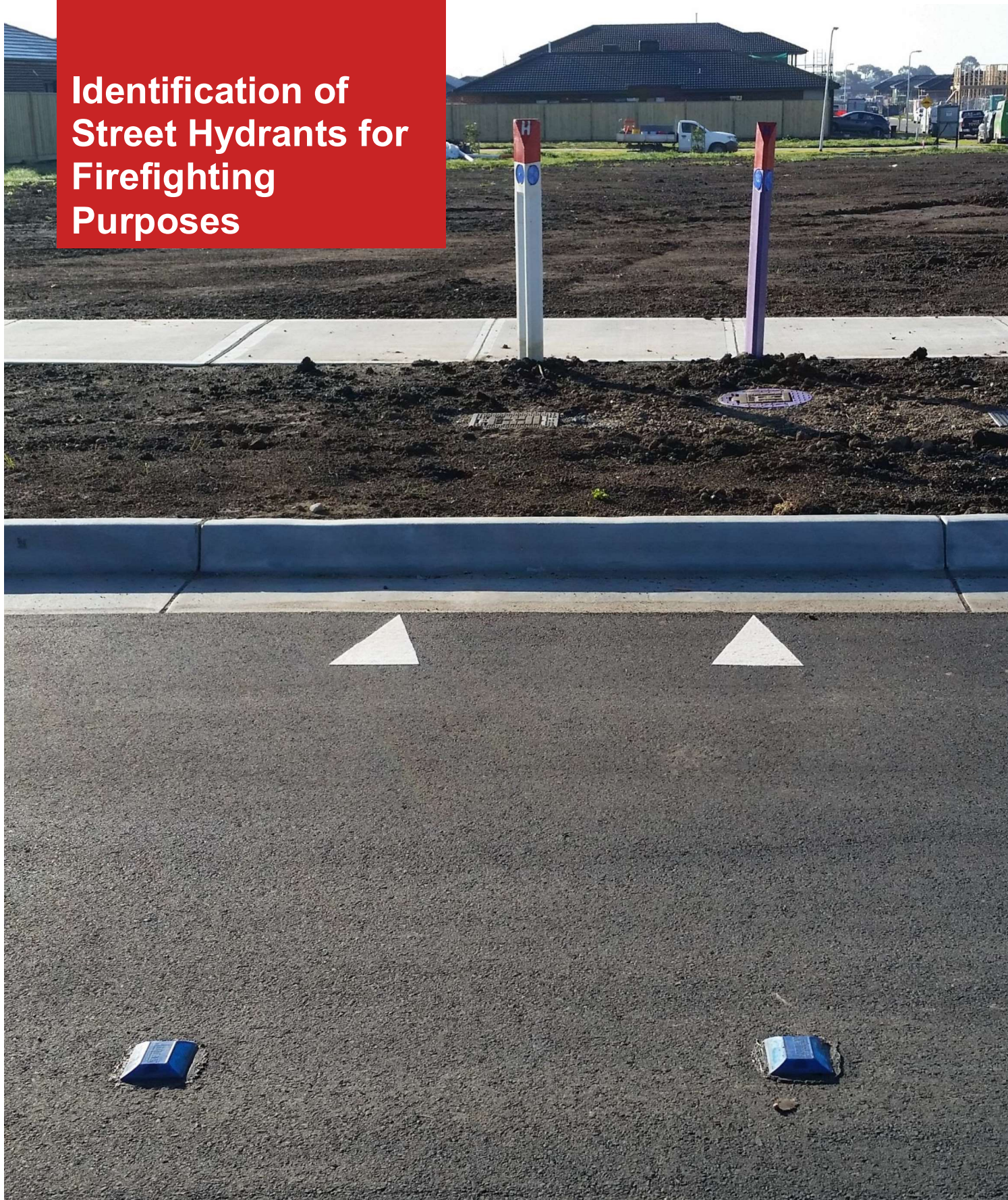

Identification of Street Hydrants for Firefighting Purposes



Published July 2019

All material in this publication is provided under a Creative Commons Attribution 4.0 international licence with the exception of any images, photographs or branding, including CFA and government logos. In some cases a third party may hold copyright on material in this publication and their permission may be required to use the material.

See creativecommons.org/licenses/by/4.0. Material obtained from this publication is to be attributed as © State of Victoria (Country Fire Authority) 2019.

Introduction

Hydrants allow Victoria's fire services to access water during emergency operations and their identification is important so that precious time is not wasted trying to locate them.

The aim of this document is to provide a reference for Councils, water authorities, contractors, land developers and any other parties responsible for provision and maintenance of the identification components of street hydrants for firefighting purposes in Victoria.

Further enquiries regarding the identification of hydrants should be directed to:

CFA

8 Lakeside Drive, Burwood East
(PO Box 701, Mt Waverley VIC, 3149)

<http://www.cfa.vic.gov.au/>

(03) 9262 8444

Table of Contents

| | |
|---|-----------|
| How to use this document | 5 |
| Variations | 5 |
| Colour standards | 5 |
| Disclaimer | 5 |
| | |
| Part A – Identification requirements for Above Ground Hydrants | 6 |
| General requirements for all above ground hydrants | 6 |
| Requirements for L Type Hydrants | 6 |
| Requirements for Pillar Hydrants | 7 |
| Requirements for Millcock Hydrants | 7 |
| Requirements for above ground hydrants in areas with sealed roads | 8 |
| Requirements for above ground hydrants that are further than 6 m from the road or otherwise concealed | 9 |
| | |
| Part B – Identification requirements for Below Ground Hydrants | 11 |
| General requirements for all below ground hydrants | 11 |
| Requirements for below ground hydrants that are further than 6 m from the road or otherwise concealed | 13 |
| | |
| Maintenance | 15 |
| | |
| Appendix 1 – Specifications for Marker Posts | 16 |
| Appendix 2 – Specifications for Road Markers | 17 |
| Blue Raised Road Reflective Marker (Cats Eye) | 17 |
| White Reflective Triangle Marker | 17 |
| Appendix 3 – Specifications for Vertical Surface Markers | 18 |

How to use this document

The identification requirements for a hydrant differ depending on the type of hydrant installed or being installed.

For **Above ground hydrants** please refer to Part A. This includes hydrants such as L type, pillar or millcocks.

For **Below ground hydrants** please refer to Part B. This includes hydrants such as ground ball, spring loaded and valve controlled.

Variations

In Victoria's alpine areas or where the identification of a hydrant as per the requirements in this document is unable to be complied with for heritage, functional or any other exceptional reason, then the circumstances and proposed identification methods should be directed to:

CFA

8 Lakeside Drive, Burwood East
(PO Box 701, Mt Waverley VIC, 3149)
<http://www.cfa.vic.gov.au/>
(03) 9262 8444

Colour standards

Any reference to Signal Red or Lilac means those colours as defined in *Australian Standard AS 2700 – 2011, Colour standards for general purposes*.

Disclaimer

Every effort has been made to ensure the information contained in this publication is free from error and / or omissions. No responsibility can be accepted by Country Fire Authority for any claims that may arise from a person acting on information contained herein.

Part A – Identification requirements for Above Ground Hydrants

General requirements for all above ground hydrants

Above ground hydrants are to have blue reflective markers directly attached to them and which face towards any direction of likely vehicle approach. The reflective markers must:

- Have a minimum surface area of 50 cm²
- Be in accordance with AS 1906.2 – 2007 – *Retroreflective materials for road traffic control purposes – Retroreflective devices (non-pavement application)*.

Requirements for L Type Hydrants

The top “cover” of L Type Hydrants must be painted in a non-reflective Signal Red colour.

An additional 70 mm strip below the Signal Red portion must be painted Lilac if the hydrant is installed on a non-drinking water main.

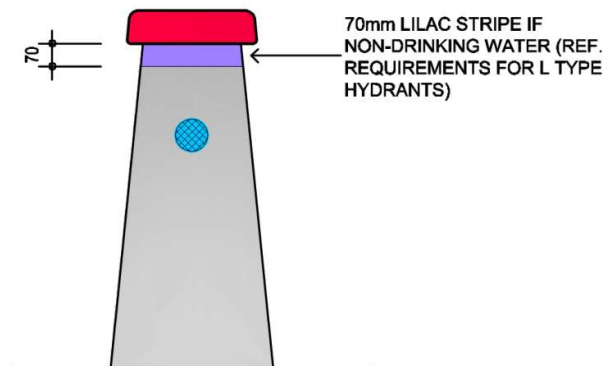

A black coloured “top” on an L type hydrant cover indicates significant pressure in the main and usage should be strongly avoided.



L Type covers must not be used to identify below ground hydrants as this will cause unnecessary delays in getting water from the hydrants.

Requirements for Pillar Hydrants

The top “cover” of Pillar Hydrants must be painted in a non-reflective Signal Red colour.

An additional 70 mm strip below the Signal Red portion must be painted Lilac if the hydrant is installed on a non-drinking water main

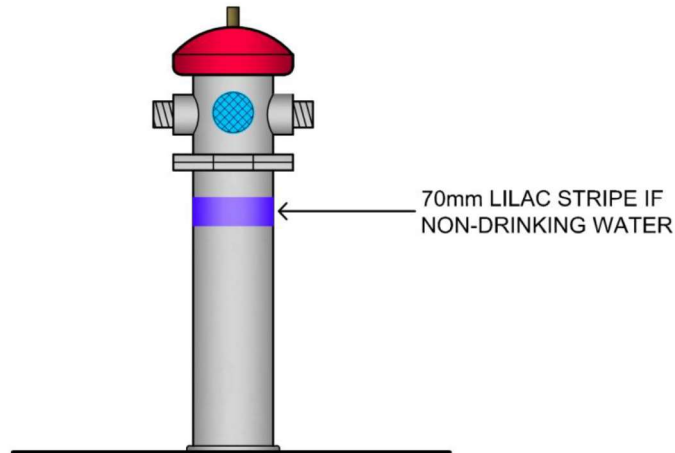

Requirements for Millcock Hydrants

At least the top 375 mm portion of Millcock Hydrants must be painted in a non-reflective Signal Red colour. An additional 70 mm strip below the Signal Red portion must be painted Lilac if the hydrant is installed on a non-drinking water main.

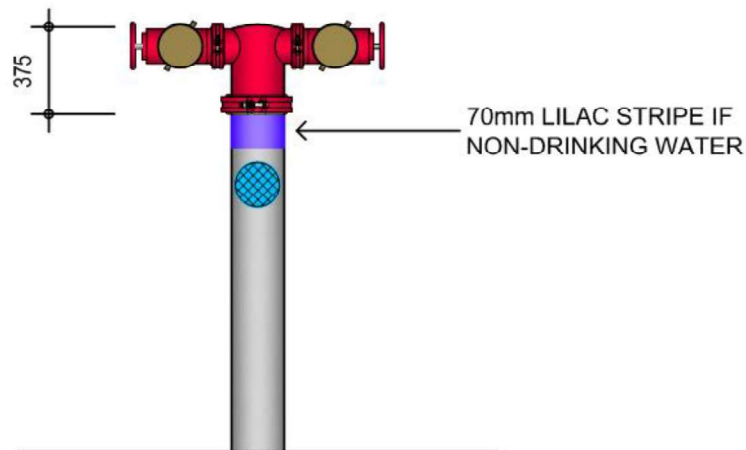

Requirements for above ground hydrants in areas with sealed roads

In areas with sealed pavement roads, a blue raised road reflective marker and white reflective triangle marker must be provided as per the specifications in Appendix 2.

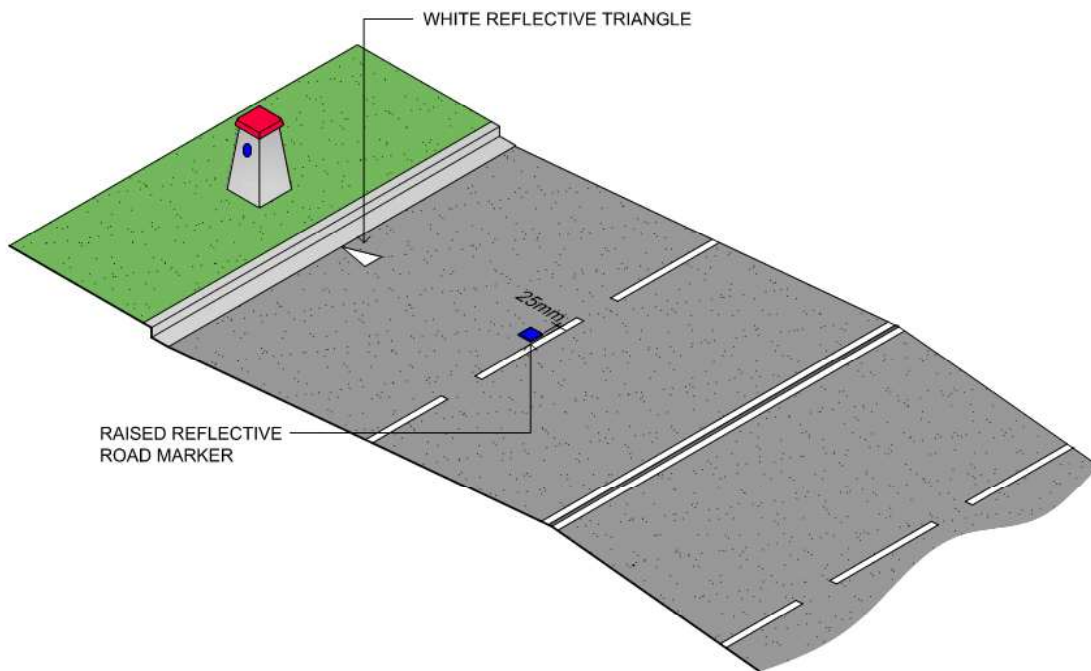
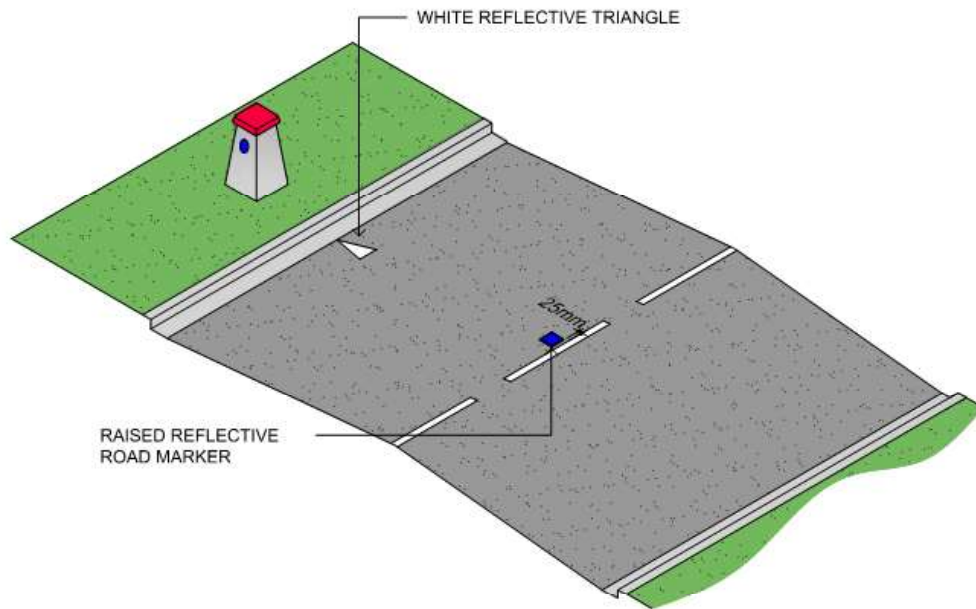

Requirements for above ground hydrants that are further than 6 m from the road or otherwise concealed

If hydrants are more than 6 m from the edge of the road (the trafficable portion), 3 m below the level of the road, 3 m above the level of the road or where concealed from view, marker posts (in accordance with Appendix 1) or vertical surface markers (in accordance with Appendix 3) must be installed.

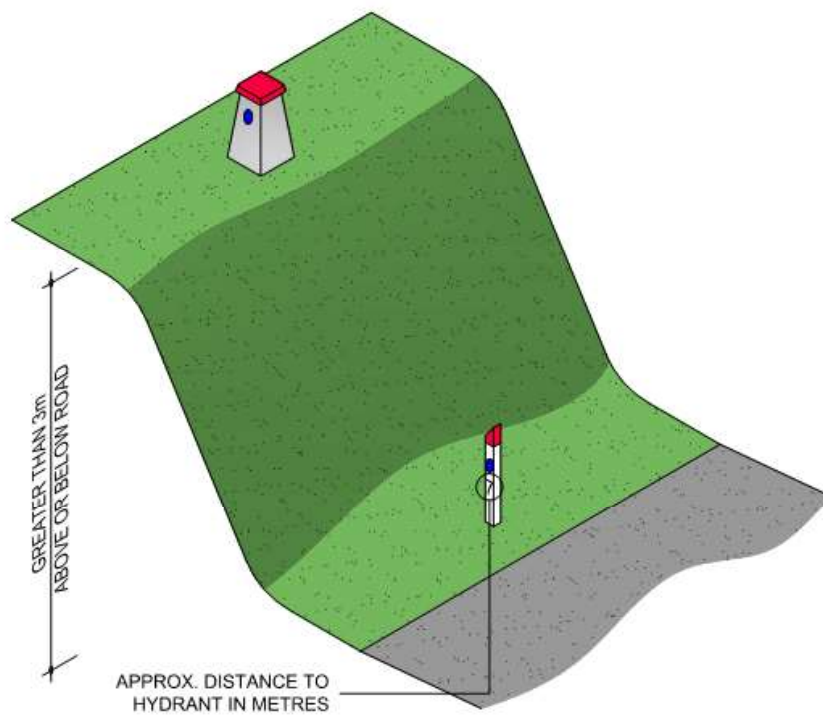
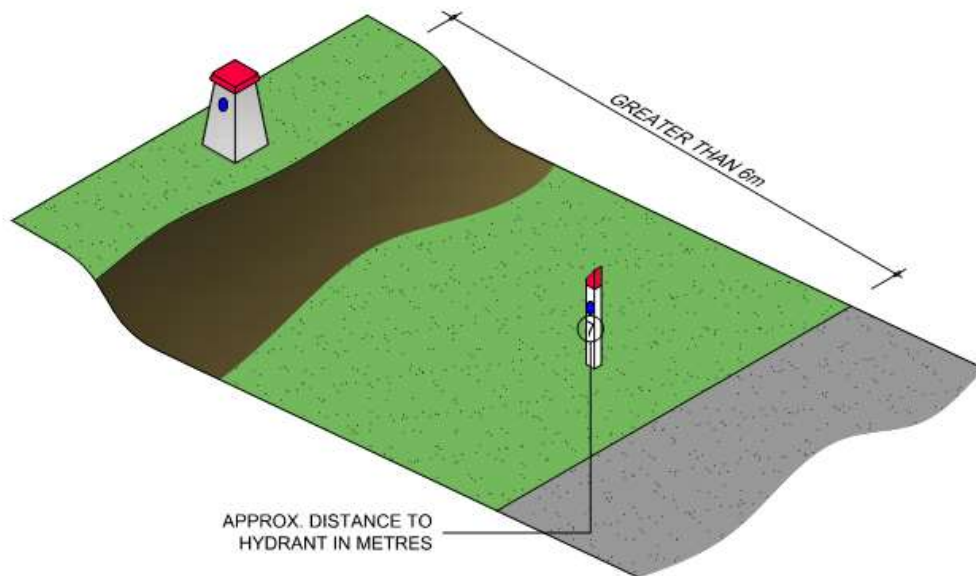

In addition to the requirements in Appendix 1, any additional marker posts required by this section shall have a distance measurement on it which indicates the approximate distance of the hydrant from the additional marker post.

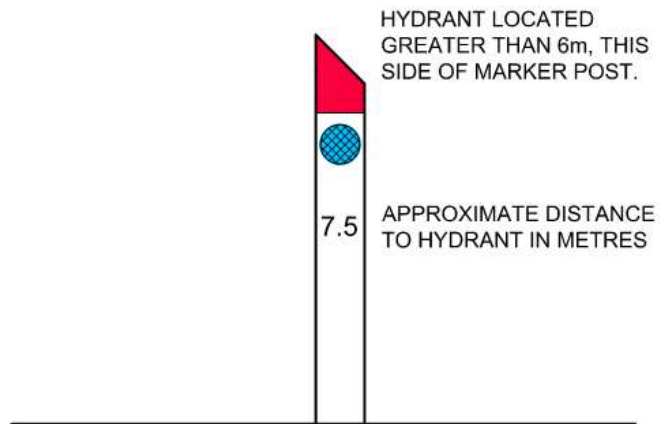

Part B – Identification requirements for Below Ground Hydrants

General requirements for all below ground hydrants

Below ground hydrants are to be provided with:

- A marker post in accordance with Appendix 1 or, in areas of high pedestrian or vehicle traffic (e.g. in the Central Business District, shopping strips, etc), vertical surface markers in accordance with Appendix 3
- A Lilac cover and surrounds if the hydrant is attached to a non-drinking water main

In any designated Bushfire Prone Area for the purposes of the Building Regulations, below ground hydrant covers must also be constructed from non-combustible materials.

Requirements for below ground hydrants in areas with sealed roads

In areas with sealed pavement roads a below ground hydrant must also be identified by a blue raised road reflective marker and white reflective triangle marker in accordance with Appendix 2.

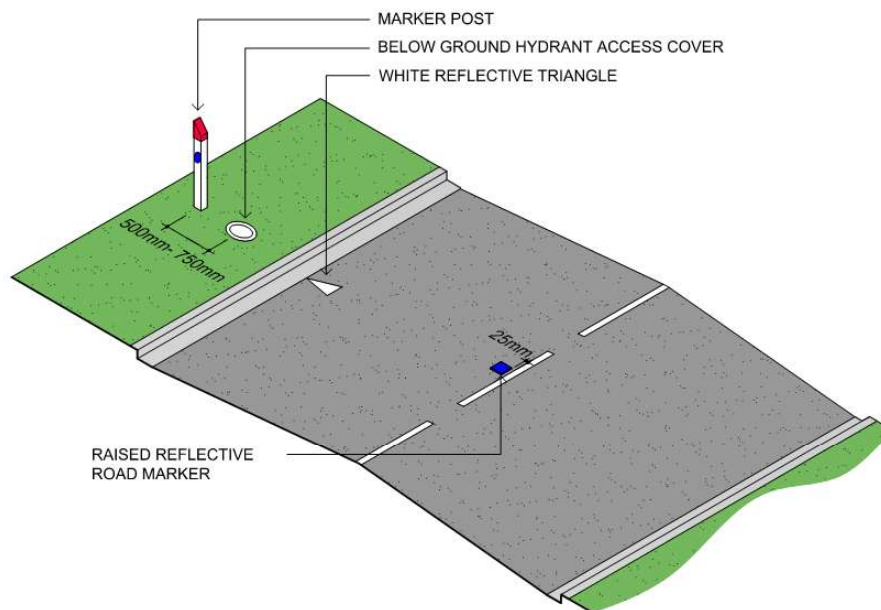

If hydrants are installed in the roadway itself then then:

- hydrant covers should be painted white.
- a cleared area of at least 2 m should be provided around the hydrant (1 m either side of the hydrant).

The cleared area should be appropriately delineated with yellow diagonal lines, no stopping/parking signs or by the installation of physical parking barriers (whatever may be the most appropriate in the circumstances).

Requirements for below ground hydrants that are further than 6 m from the road or otherwise concealed

If hydrants are more than 6 m from the edge of the road (the trafficable portion), greater than 3 m below the road level, less than 3 m above the road level or where otherwise concealed from view, marker posts (in accordance with Appendix 1) or vertical surface markers (in accordance with Appendix 3) must also be installed to ensure that fire fighters are directed easily to the location of the hydrant.

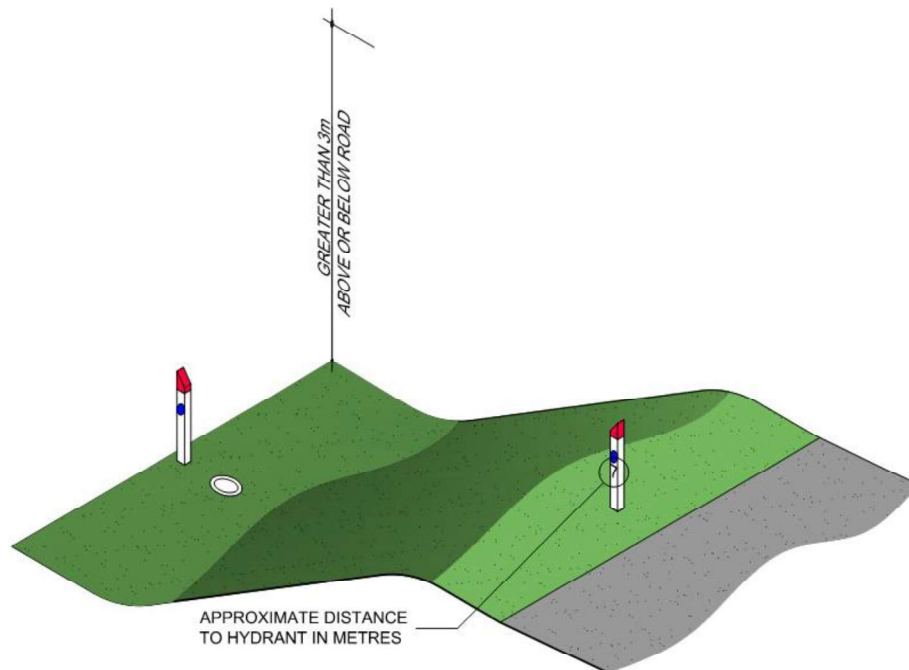
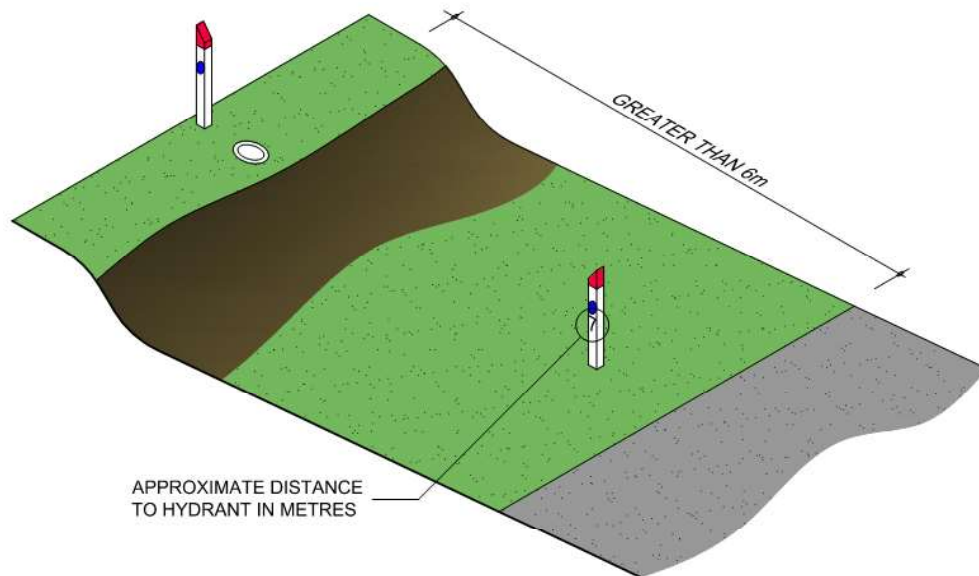

In addition to the requirements in Appendix 1, any additional marker posts required by this section shall have a distance measurement on it which indicates the approximate distance of the hydrant from the additional marker post.

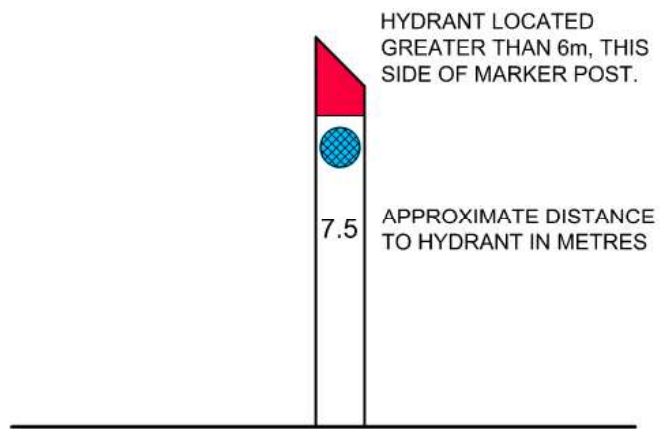

Maintenance

Victoria's fire services expect that all parties responsible for the maintenance of hydrants should implement a program that ensures:

- All hydrants are inspected on a regular basis.
- All means of hydrant identification are maintained in accordance with this document on an ongoing basis.

Programs which encourage the public to identify and report any issues to the relevant party are strongly encouraged.

Appendix 1 – Specifications for Marker Posts

Where required by Part A or Part B of this document, marker posts must:

- Be at least 1000 mm in height above finished ground level.
- Be installed no less than 500 mm and not more than 750 mm from the hydrant that they are identifying (excluding additional marker posts required by Part A or Part B).
- Have a non-reflective Signal Red top of at least 200 mm with the remainder of the post being coloured:
 - White if identifying a hydrant on a potable water main
or
 - Lilac if identifying a hydrant on a main for non-drinking water; and
- Include a method of indicating the direction of the hydrant (such as a tapering top which points downwards towards the hydrant location)
- Installed in such a manner so that they are not easily removed (e.g. in concrete or as per manufacturers specifications)
- Include a blue reflective marker which faces toward any direction of likely vehicle approach. Reflective markers must
 - Have a minimum surface area of 50 cm².
 - Be in accordance with *Australian Standard AS 1906.2 – 2007 – Retroreflective materials for road traffic control purposes – Retroreflective devices (non-pavement application)*.
- Be constructed of non-combustible materials if installed in any Designated Bushfire Prone Area for the purposes of the Building Regulations

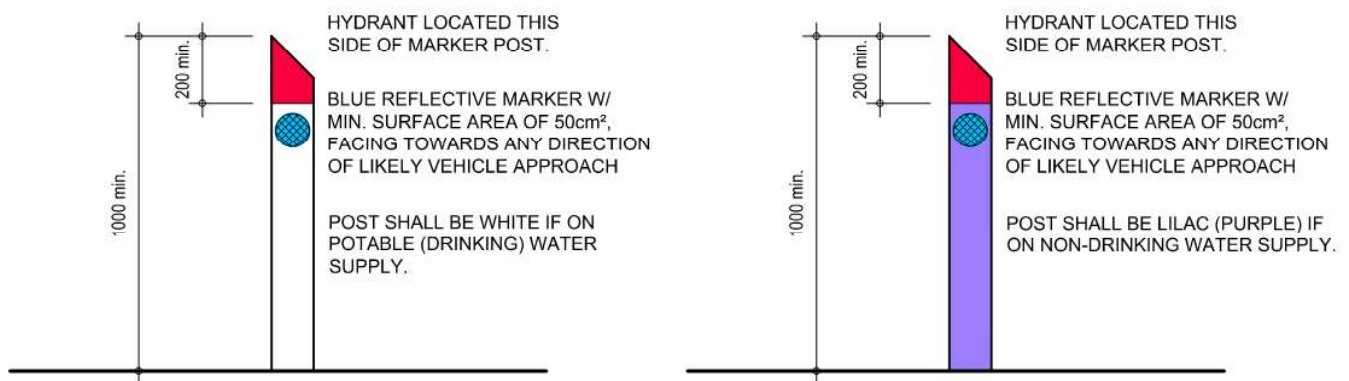

Appendix 2 – Specifications for Road Markers

Where required by Part A or Part B of this document, the following markers are to be installed:

Blue Raised Road Reflective Marker (Cats Eye)

Blue raised road reflective markers must comply with *Australian Standard AS 1906.3 – 1992 – Retroreflective materials and devices for road traffic control purposes – Raised pavement markers (retroreflective and non-retroreflective)*

They are to be installed 25 mm from:

- the centre line of the road on single carriageways (on the hydrant side)
or
- the closest lane (on the hydrant side) on multiple carriageways and divided roads.

White Reflective Triangle Marker

White reflective triangle markers must:

- meet the requirements of *Australian Standard AS 4049.2 – 2005 - Paints and related materials - Pavement marking materials - Thermoplastic pavement marking materials - For use with surface applied glass beads* or as per water agency products catalogue.
or
- using VicRoads approved marking paint.

They are to be approximately 450 mm long by 250 mm wide, the tip of the triangle must point to the location of the hydrant and they are to be installed on the edge of the road (curb side, but not on the curb itself).

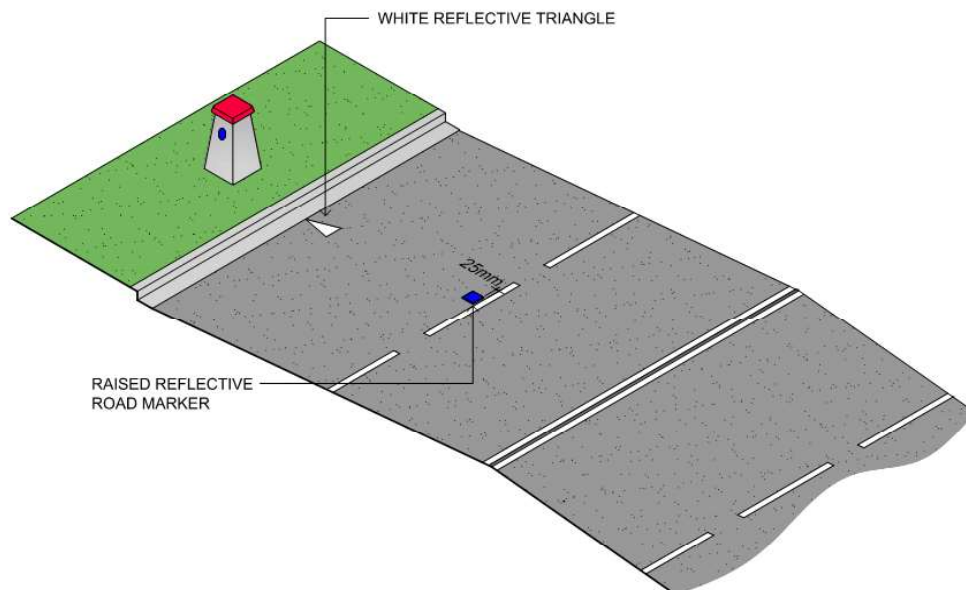

Appendix 3 – Specifications for Vertical Surface Markers

Where permitted by Part A or Part B of this document, vertical surface markers shall meet the following specifications.

- Two vertical surface markers shall be provided with one being the primary and one being the secondary.
- The primary marker must be at least 150 mm by 225 mm in size and include a blue reflective section of 100 mm by 100 mm.

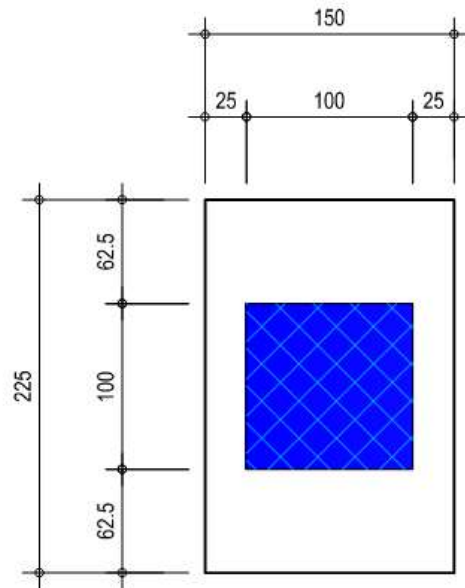

- The secondary marker must be at least 150 mm by 112.5 mm in size and include a blue rectangular reflective section of 100 mm by 50 mm.

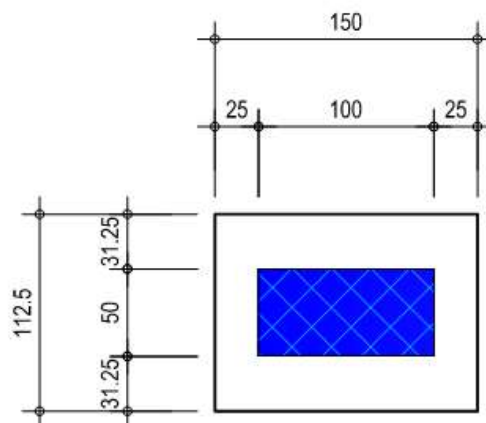

- The blue reflective section must be of a material which complies with *Australian Standard AS 1906.1-2007 Retroflective materials and devices for road traffic purposes – class 1 retroflective materials* and be fixed in the center of the marker.

- The primary marker is to be installed on a vertical surface pointing towards the location of the hydrant. The secondary marker is to be installed on the opposite side to indicate the location of the primary marker (where possible).

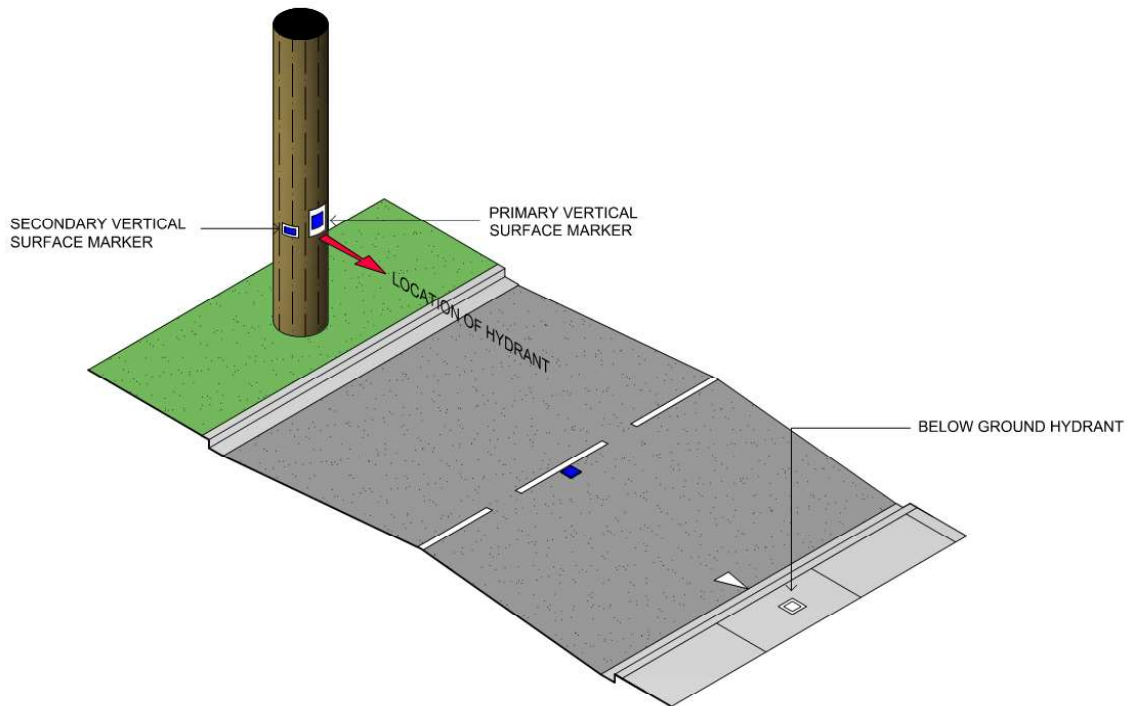

- The preferred height of installation is between 1.8 m and 2 m, however this height may be varied depending on the availability of vertical surfaces near the hydrant.
- Both the primary and secondary markers are to be constructed from a zinc coated steel sheet which is pre-painted white, or a white vinyl sheet.